

# Chapter 1

## General Introduction

### 1.1 Inference, Observation, Communication

Much of our interaction with each other in daily life has to do with information processing and reasoning about knowledge and ignorance of the people around us. If I ask a simple question, like “Can you tell me where to find the Opera House?”, then I convey the information that I do not know the answer, and also, that I think that you may know. Indeed, in order to pick out the right person for asking such informative questions, we need to reason about knowledge of others. It is our ability to reason in the presence of other reasoning agents that has made us historically so successful in debate, organization, and in planning collective activities. And it is reasoning in this broad sense that this course is about.

We will study informational processes of inference and information update – and while we can start dealing with these for single agents, our theories must also work interactively when many agents exchange information, say, in a conversation or a debate. As we proceed, you will see many further aspects of this program, and you will learn about mathematical models for it, some quite recent, some already very old.

**Reasoning and Proof** While reasoning in daily life and solving practical tasks is important, many logical phenomena become more pronounced when we look at specialized areas, where our skills have been honed to a greater degree.

To see the power of pure inference unleashed, think of mathematical proofs. Already in Greek Antiquity (and in parallel, in other cultures), logical inference provided a searchlight toward surprising new mathematical facts. In our later chapter on Proof, we will give examples, including the famous Pythagorean proof that  $\sqrt{2}$  is not a rational number. The Holy Writ of this tradition are Euclid’s *Elements* from around 300 BC with its formal set-up of axioms, definitions, and theorems for geometry.



(1.1)

Indeed, mathematical methods have deeply influenced the development of logic. They did so in two ways. First, mathematical proof is about the purest form of inference that exists, so it is an excellent ‘laboratory’ for studying inference. But also, mathematics is about the clearest way that we have for modeling phenomena and studying their properties, and logical systems of any kind, even when dealing with daily life, use mathematical techniques.

**Reasoning and Observation** Combinations of inference with other information sources drive the natural sciences, where experiments provide information that is just as crucial as mathematical proof. Observations about Nature made by scientists involves the same sort of information update as in simple question answering. Seeing new facts removes uncertainty. And the art is to ask the right questions, to find the right mixtures of new evidence and deduction from what we have seen already.

The same skill actually occurs in other specialized practices. Conan Doyle’s famous detective Sherlock Holmes is constantly thinking about what follows from what he has seen already, but he also uses his powers of deduction to pinpoint occasions where he needs new evidence. In a famous story, the dog did not bark at night-time (and so, the intruder must have been known to the dog), but this conclusion also directs attention toward making further observations, needed to see which of the various familiar persons committed the crime.

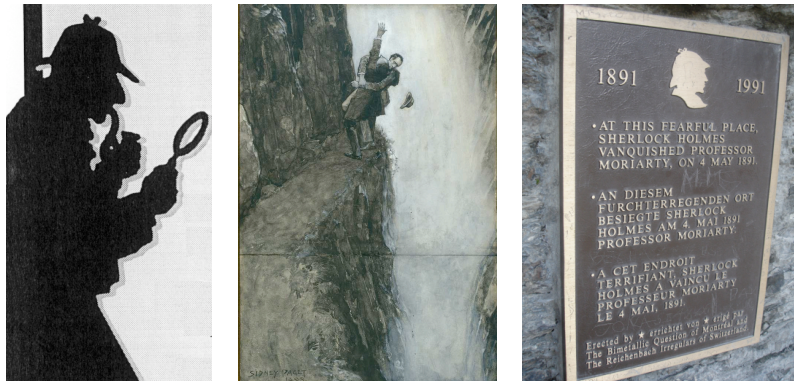

(1.2)

**Reasoning and Argumentation** From crime it is only one step to lawyers and courts. Legal reasoning is another major tradition where logic is much in evidence, and we will return to this later.

## 1.2 The Origins of Logic

Logic as a systematic discipline dates back two and a half millennia: younger than Mathematics or the Law, but much older than most current academic disciplines, social institutions, or for that matter, religions. Aristotle and the Stoic philosophers formulated explicit systems of reasoning in Greek Antiquity around 300 BC.



(1.3)

Aristotle appearing on two Greek postal stamps      The early Stoic Zeno of Citium

Independent traditions arose around that time in China and in India, which produced famous figures like the Buddhist logician Dignaga, or Gangesa, and this long tradition lives on in some philosophical schools today. Through translations of Aristotle, logic also reached the Islamic world. The work of the Persian logician Avicenna around 1000 AD was still taught in madrassa's by 1900. All these traditions have their special concerns and features, and there is a growing interest these days in bringing them closer together.

We mention this point because the cross-cultural nature of logic is a social asset beyond its scientific agenda.



(1.4)

Mo Zi, founder of Mohism    Dignaga, Indian Buddhist Logician    Avicenna, Persian Logician

Still, with all due respect for this historical past that is slowly coming to light, it seems fair to say that logic made a truly major leap in the nineteenth century, and the modern logic that you will see in this course derives its basic mind-set largely from the resulting golden age of Boole, Frege, Gödel, and others: a bunch of European university professors, some quite colourful, some much less so.

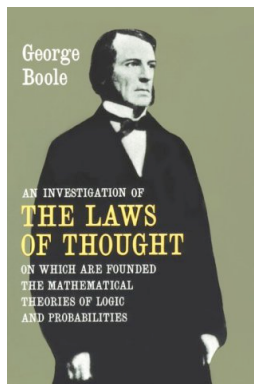

George Boole on the cover of the 'Laws of Thought' (1847), the book that created propositional logic, the theme of the next chapter.

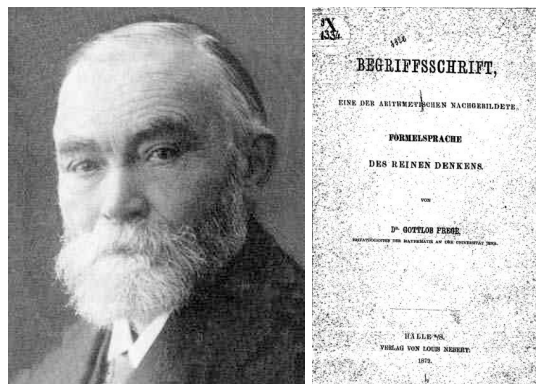

(1.5)

Gottlob Frege with on the right the first page of his 'Begriffsschrift' (1879), with the system of first-order predicate logic that can analyze much of mathematics.

Even so, it remains an intriguing and unsolved historical question just how and why logic arose — and we will have more to say on this below. The standard story is that great thinkers like Aristotle suddenly realized that there is structure to the human reasoning that we see all around us. Some patterns are valid and reliable, while others are not. But it has also been suggested that an interest in logic arose out of philosophical, mathematical, juridical, or even political practice. Some 'moves' worked, others did not – and people became curious to see the general reasons why.

## 1.3 Uses of Inference

The TV has gone dark. If it goes dark, this is due to the apparatus or the remote (or both). But the remote is working, so it must be the apparatus, and we must start repairs there. This pattern involves a logical key-word, the *disjunction* ‘or’:

$$A \text{ or } R, \text{ not } R. \text{ So: } A. \quad (1.6)$$

In pure form, we can also see this pattern at work in solving Sudoku puzzles. Logic also helps create new Sudoku puzzles. Start with any complete nine-digit diagram. Now pick a random slot and remove the digit in that slot. The remaining digits in the diagram still completely determine what should be in the open slot, for the digit in that slot follows by logical inference (or: by valid inference) from the other digits and the general sudoku constraints. In this way, one can go on picking filled positions at random, and checking if the digit in that position still follows from others by a valid inference. Keep doing this until no longer possible. You have now generated a minimal puzzle, and since your steps are hidden, it may take readers quite a while to figure out the unique solution.

Cognitive scientists have suggested that the primary use of logic may have been in planning. Clearly, thinking about constraints and consequences of tasks beforehand is an immense evolutionary advantage. Here is a simple illustration.

**Planning a party** How can we send invitations given the following constraints?

- (i) John comes if Mary or Ann comes.
- (ii) Ann comes if Mary does not come. (1.7)
- (iii) If Ann comes, John does not.

In the chapter on propositional logic, you will learn simple techniques for solving this: for now, just try! (Here is a hint: start out with a ‘maximal’ invitation list *John, Ann, Mary*, and check what you have to drop to satisfy the constraints. Bear in mind that there may be several solutions to this.)

**Legal reasoning** We also said that daily skills can be optimized for special purposes. As we said already, inference is crucial to legal reasoning, and so is the earlier-mentioned multi-agent feature that different actors are involved: defendant, lawyer, prosecutor, judge.

The prosecutor has to prove that the defendant is guilty ( $G$ ) on the basis of the available admissible evidence ( $E$ ), i.e., she has to prove the conclusion  $G$  from evidence  $E$ . But the usual ‘presumption of innocence’ means that the lawyer has another logical task: viz. making it plausible that  $G$  does not follow from  $E$ . This does not require her to demonstrate that her client is innocent: she just needs to paint one scenario consistent with the evidence  $E$  where  $G$  fails, whether it is the actual one or not.

**Logical key-words** There are certain logical key-words driving patterns of inference. Expressions like ‘not’, ‘and’, ‘or’, ‘if then’ are sentence forming constructions that classify situations as a whole. What we mean by this is that these expressions can be used to construct new sentences from existing sentences. From “it is raining” to “it is not raining”. From “it is raining” and “it is wet” to “if it is raining then it is wet”, and so on.

But there are other expressions that tell us more about the internal structure of these situations, in terms of objects and their properties and relations. “Hans is friendly” ascribes a property to a person. “Hans and Jan are colleagues” describes a relation between two persons. Historically, the most important example are quantifiers, expressions of quantity such as ‘all’, ‘every’, ‘some’ or ‘no’. “All logicians are friendly” describes how the properties of being a logician and being friendly are related, using the quantifier ‘all’.

The view of inference as the result of replacing some parts in expressions by variable parts, so that only logical key-words and variables remain, can already be found in the work of the Bohemian philosopher and priest Bernhard Bolzano (1781 – 1848).



(1.8)

Bernard Bolzano

Aristotle’s syllogisms listed the basic inference patterns with quantifiers, such as

All humans are animals, no animals are mortal. So, no humans are mortal. (1.9)

This is a valid inference. But the following is not valid:

Not all humans are animals, no animals are mortal. So, some humans are mortal. (1.10)

Syllogistic forms were long considered the essence of logical reasoning, and their format has been very influential until the 19th century. Today, they are still popular test cases for psychological experiments about human reasoning.

Quantifiers are essential to understanding both ordinary and scientific discourse. If you unpack standard mathematical assertions, you will find any amount of stacked quantifiers. For instance, think of saying that 7 is a *prime number*. This involves:

All of 7’s divisors are either equal to 1 or to 7, (1.11)  
where  $x$  divides  $y$  if for some  $z$ :  $x \cdot z = y$ .

Here ‘all of’ and ‘for some’ are the quantifiers that provide the logical glue of the explanation of what it means to be prime, or to be a divisor. Other examples with many quantifiers occur in Euclid’s geometry and spatial reasoning in general.

We will devote two entire chapters to the logic of the quantifiers ‘all’, ‘some’, given its central importance. Actually, natural language has many further quantifier expressions, such as ‘three’, ‘most’, ‘few’, ‘almost all’, or ‘enough’. This broad repertoire raises many issues of its own about the expressive and communicative function of logic, but we sidestep these here.

Many further logical key-words will emerge further on in this course, including expressions for reasoning about knowledge and action.

Another crucial feature of logic, that makes it a true scientific endeavour in a systematic sense, is the turning of human reasoning to itself as a subject of investigation. But things go even one step further. Logicians study reasoning practices by developing mathematical models for them – but then, they also make these systems themselves into a new object of investigation.

**Logical systems** Indeed, Aristotle already formulated explicit logical systems of inference in his Syllogistics, giving all valid rules for syllogistic quantifier patterns. Interestingly, Aristotle also started the study of grammar, language looking at language — and earlier than him, the famous Sanskrit grammarian Panini had used mathematical systems there, creating a system that is still highly sophisticated by modern standards:



(1.12)

This mathematical system building tradition has flourished over time, largely (but not exclusively) in the West. In the nineteenth century, George Boole gave a complete analysis of propositional logic for reasoning with sentential operators like ‘not’, ‘and’, ‘or’, that has become famous as the ‘Boolean algebra’ that underlies the switching circuits of your computer. Boole showed that all valid principles of propositional reasoning can be derived from a simple calculus, by purely algebraic manipulations. We will explain how this works later on in this course.

Subsequently, Frege gave formal systems for reasoning with quantifiers in ways that go far beyond Aristotle’s Syllogistic. Over time, systems in this line have proved strong enough to formalize most of mathematics, including its foundational *set theory*.

**Foundations of mathematics** Through this process of scrutiny, mathematical and logical theories themselves become objects of investigation. And then, some startling discoveries were made. For instance, here is the so-called Russell Paradox from the foundations of set theory.

Set theory is a general way of talking about collections of entities. What the Russell paradox tells us is that we have to be very careful in how to express ourselves in talking about collections of entities. For suppose anything goes in defining sets, so that, if we have a description we can construct the set of all things satisfying the description. Then the following can happen.

Some sets contain themselves as a member (e.g., the set of all non-teaspoons is not a teaspoon, so the set of non-teaspoon has itself as a member). Others do not (for instance, the set of all teaspoons is not itself a teaspoon.) Now consider the set  $R$  of all sets that do not have themselves as members. It is easy to see that  $R$  is a member of  $R$  if and only if  $R$  is *not* a member of  $R$ : and that is a contradiction.

The sort of reasoning that leads to this paradox will be taken up in several later chapters. The formal definition of the Russell set  $R$  is:  $R = \{x \mid x \notin x\}$ . The paradoxical statement is:  $R \in R$  if and only if  $R \notin R$ . If you have never seen the symbol  $\in$  or the bracket notation  $\{x \mid \dots\}$  then you should at some point consult Appendix A to catch up with the rest of us.

The foundational problems in the development of logic illustrated by Russell's paradox led to the so-called foundational study of mathematics, which investigates formal properties of mathematical theories, and power and limits of proofs. A famous name here is Kurt Gödel, probably the greatest figure in the history of logic. His incompleteness theorems are fundamental insights into the scope and reliability of mathematics, that got him on the TIME 2001 list of most influential intellectuals of the twentieth century. But in Amsterdam, we also cite our own L.E.J. Brouwer, the father of 'intuitionistic logic', an important program in the foundations of mathematics and computation. These mathematical theoretical aspects of logic belong more properly to an advanced course, but we will give you some feeling for this theme further on in this book.



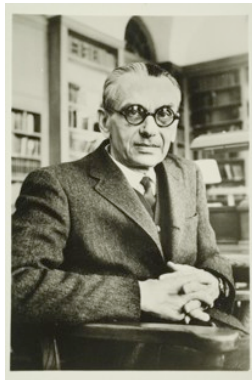

Kurt Gödel



Brouwer on a Dutch post stamp

(1.13)

## 1.4 Logic and Other Disciplines

Looking at the list of topics discussed above, you have seen switches from language and conversation to mathematics and computation. Indeed, in a modern university, logic lies at a cross-roads of many academic disciplines. This course will make you acquainted with a number of important *systems* for doing logic, but it will also draw many connections between logic and related disciplines. We have already given you a taste of what logic has to do with *mathematics*. Mathematics supplies logic with its techniques, but conversely, logic can also be used to analyze the foundations of mathematics. Now we look at a few more important alliances.

**Logic, language and philosophy** Perhaps the oldest connection of logic is with *philosophy*. Logic has to do with the nature of assertions, meaning, and knowledge, and philosophers have been interested in these topics from the birth of philosophy. Logic can serve as a tool for analyzing philosophical arguments, but it is also used to *create* philosophical systems. Logical forms and calculating with these is a role model for conceptual abstraction. It has even been claimed that logical patterns of the sort sketched here are close to being a ‘universal language of thought’.

But it will also be clear that logic has much to do with *linguistics*, since logical patterns arise from abstraction out of the grammar of ordinary language, and indeed, logic and linguistics share a long history from Antiquity through the Middle Ages.

**Logic and computation** Another long-standing historical theme interleaves logic and *computation*. Since the Middle Ages, people have been fascinated by machines that would

automate reasoning, and around 1700, Leibniz



Gottfried Wilhelm von Leibniz

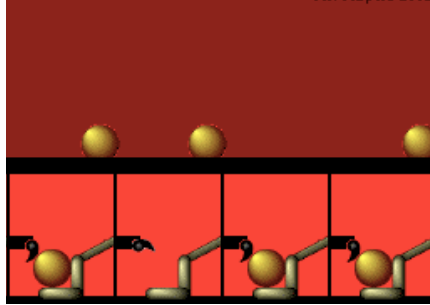

(1.14)

The first binary addition mechanism as described by Leibniz in a paper called 'Mechanica Dyadica' (around 1700)

realized that logical inference may be viewed as a sort of computation, though not with ordinary but with binary numbers. A straight line runs from here to modern computers and computer science, and the seminal work of Turing and others.



Alan Turing

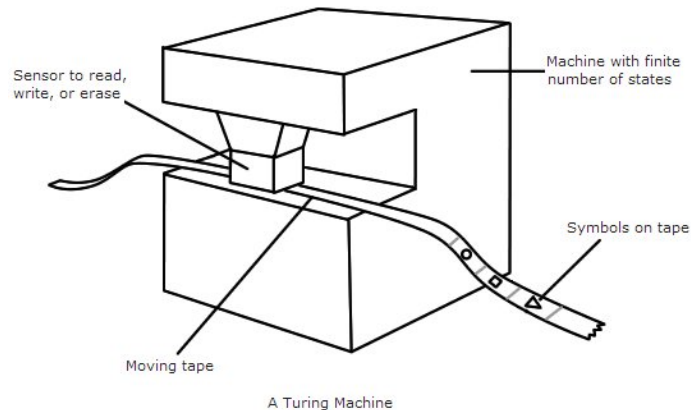

(1.15)

A 'Turing Machine'

**Logic and games** While mathematics, philosophy, linguistics, and computer science are old neighbours of logic, new interfaces keep emerging. We end with one directed toward the social and behavioural sciences. As we have said before, logic had its origins in a tradition of conversation, debate, and perhaps legal procedure. This brings us back to our earlier theme that much logical behaviour is interactive, crucially involving other persons.

Argumentation itself is a key example. There are different parties playing different roles, and reacting to each other over time. This clearly has the structure of a game. In such a game logical operations like 'or', 'and' and 'not' function as a sort of 'switches', not just in a Boolean computer, but also in discussion. When I defend that ' $A$  or  $B$ ', then you can hold me to this, and I have to choose eventually which of the two I will defend. Thus, a disjunction offers a choice to its defender — and likewise, a conjunction ' $A$  and  $B$ '

offers a choice to the attacker: since the defender is committed to both parts. Interesting interactions also arise by means of the third item of Boolean algebra: logical negation. This triggers a role switch: defending ‘not  $A$ ’ is attacking ‘ $A$ ’, and vice versa. Indeed, being able to ‘put yourself in another person’s place’ has been called the quintessential human cognitive achievement.

In this way, logic comes to describe the structure of rational interaction between conversation partners. Traditions of vigorous regimented logical debating games flourished in the Middle Ages, and they still do in some parts of the world:



(1.16)

Karma Guncho, ten monasteries battle each other on Buddhist philosophy using logical analysis.

In this game setting, we may call an inference valid if the defender of the conclusion has a ‘winning strategy’: that is, a rule for playing which will always lead her to win the game against any defender of the premises, whatever that person brings up over time.

But if logic has much to do with games, then it also has links with economic game theory, and not surprisingly, this is another flourishing interface today. We will develop this topic in greater depth in a separate chapter, but now you know why.

## 1.5 Overview of the Course

In this course, logic will be presented as a key element in the general study of reasoning, information flow and communication: topics with a wide theoretical and practical reach. The course starts with introductions to three important systems of reasoning: propositional logic (Chapter 2), syllogistics (Chapter 3), and predicate logic (Chapter 4). Together, these describe situations consisting of objects with a great variety of structure, and in doing so, they cover many basic patterns that are used from natural language to the depths of mathematics.

Next, we move on to the newer challenges on a general agenda of studying information flow. The first is agents having information and interacting through questions, answers, and other forms of communication. This social aspect is crucial if you think about how we use language, or how we behave in scientific investigation. We will model observation and reasoning in a multi-agent setting, introducing the logic of knowledge in Chapter 5.

To model the dynamic aspect of all this, we turn to the basic logic of action in Chapter 6. And Chapter 7 takes up a more recent theme: the use of games as a model of interaction. These bring together many of the separate topics in the course so far.

The next group of chapters then develop three logical methods more in detail. Chapter 8 is about precise ways of testing logical validity, that give you a sense of how a significant logical calculus really works. Chapter 9 goes into mathematical proof and its structures. Chapter 10 gives more details on the many relations between logic and computation.

In all of these chapters, and even more in the internet version of this text, you will find links to topics in philosophy, mathematics, linguistics, cognition and computation, and you will discover that logic is a natural ‘match-maker’ between these disciplines.

We have tried to give an indication of the difficulty of the exercises, as follows: ♡ indicates that a problem is easy (solving the problems marked as ♡ can be used as a test to check that you have digested the explanations in the text), ♠ indicates that a problem is a bit harder than average, and ♠♠ indicates that a problem is quite hard. If you feel you can handle an extra challenge, you are encouraged to try your hand at these.